

REV.	DESCRIPTION	DATE
1	PRELIMINARY	Sep.25,2018

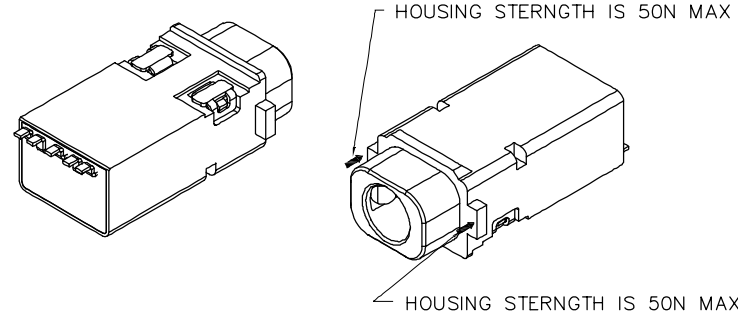
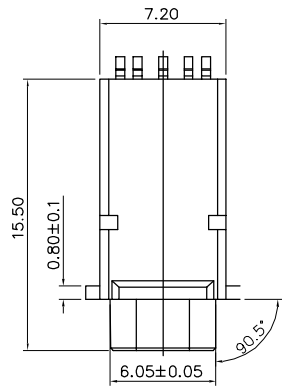

MATERIALS

1. HOUSING : PA9T UL94V-0 BLACK.
2. COVER : PA9T UL94V-0 BLACK.
3. TERMINAL : COPPER ALLOY.
PLATING : GOLD PLATED NICKEL.

SPECIFICATION

1. CURRENT RATING : 0.5A. MAX.
2. DIELECTRIC WITHSTANDING VOLTAGE :
500V AC R.M.S. FOR ONE MINUTE.
3. INSULATION RESISTANCE : 100MΩ MIN AT 500V DC.
4. CONTACT RESISTANCE : 30m OHMS MAX.
5. MATING FORCE : 0.4kgf~2.0kgf.
6. UNMATING FORCE : 0.4kgf~2.0kgf.
7. DURABILITY : 5000 CYCLES.

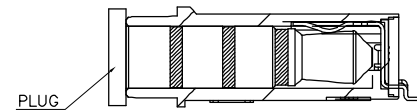
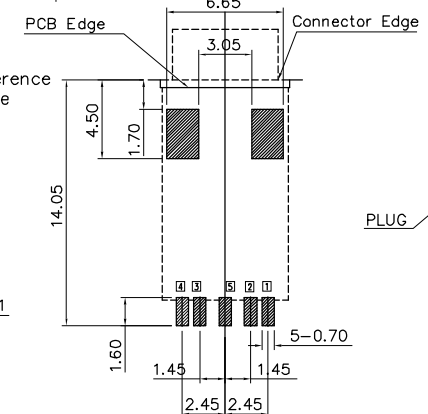
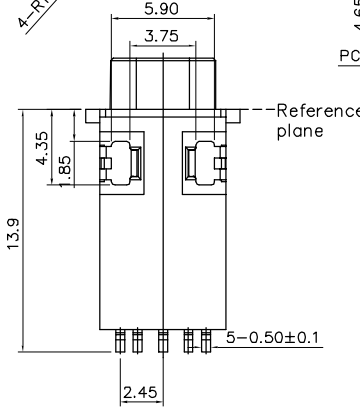
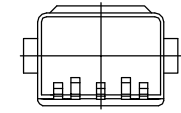
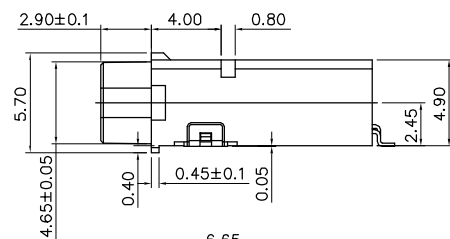
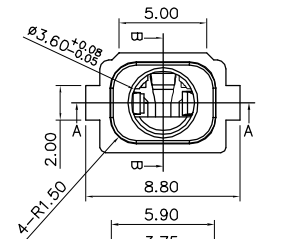

SEC: B-B
IMAGE OF PLUG MATCH WITH CONTACT POINT

PART NUMBER INFORMATION :

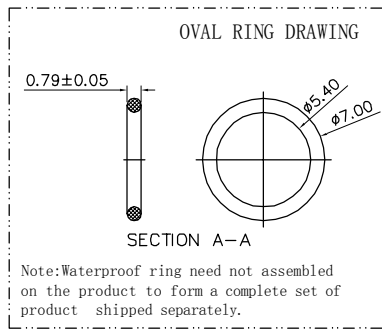
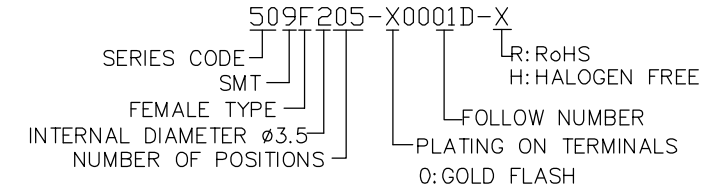

RECOMMENDED P.C.B LAYOUT
TOLERANCE : ±0.05(TOP VIEW)

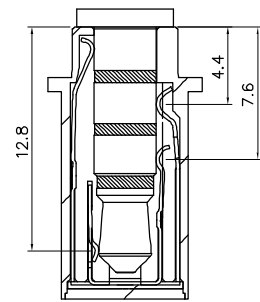
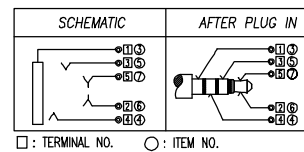

SEC: A-A
IMAGE OF PLUG MATCH WITH CONTACT POINT

TOLERANCE		DRAWER		 ASTRON TECHNOLOGY CORP.
.0=±0.30		DLM		
.00=±0.25		CHECK		NAME
.000=±0.20		SPURD FU		
ANG.=±3°		APP'D		MINIATURE JACK
		SPURD FU		
		PRODUCT SPEC.		DRAW NO.
UNITS : mm				
SCALE	SIZE	SHEET	REV.	509F205-X0001D-X
NONE	A4	1 OF 1	1	