

REV.	DESCRIPTION	DATE
A	N22'11003	Nov.09, 2022
B	N23'02003	Feb.23, 2023

MATERIALS

1. HOUSING : LCP (UL94V-0), BLACK.
2. TERMINAL : HIGH COPPER ALLOY,
GOLD PLATED ON CONTACT AREA.
TIN PLATED ON SOLDER TAIL,
UNDER NICKEL PLATED.
3. SHELL : COPPER ALLOY, NICKEL PLATED.

SPECIFICATION

1. CURRENT RATING : 0.5A. MAX.
2. DIELECTRIC WITHSTANDING VOLTAGE :
500V AC R.M.S. FOR ONE MINUTE.
3. INSULATION RESISTANCE : 100MΩ MIN. AT 500V DC.
4. CONTACT RESISTANCE : 30mΩ MAX.
5. OPERATING TEMPERATURE : -25°C TO +85°C.
6. DURABILITY : 10000 CYCLES.
7. MATING FORCE : 4.5kgf MAX.
8. UNMATING FORCE : 1.0kgf MIN.

PART NUMBER INFORMATION

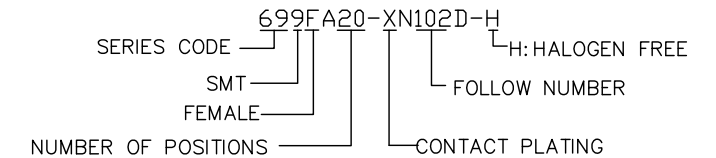

DESCRIPTION OF PLATING ON TERMINALS			
NO.	EXPLAIN	NO.	
0	GOLD FLASH	3	GOLD 15u"
6	GOLD 30u"		
TOLERANCE .0=±0.25 .00=±0.15 .000=±0.05 ANG.=±3°		DRAWER <i>Shen</i> CHECK <i>Hony</i> APP'D <i>Hony</i>	
UNITS : mm		NAME Astron ASTRON TECHNOLOGY CORP.	
SCALE NONE		PRODUCT SPEC. Erh FS DP Receptacle Connector (Type1), SMT TYPE (SCREW THREAD M2)-8.78mm	
SIZE A4		DRAW NO. R699FA20-XN102D-H	
SHEET 1 OF 2		REV. B	

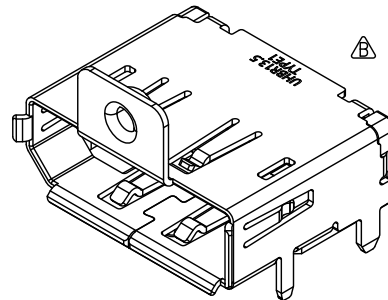
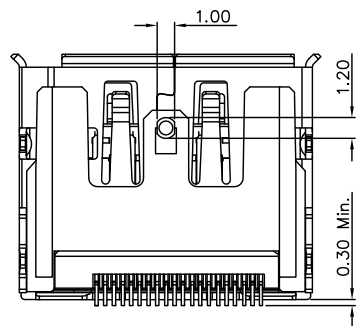
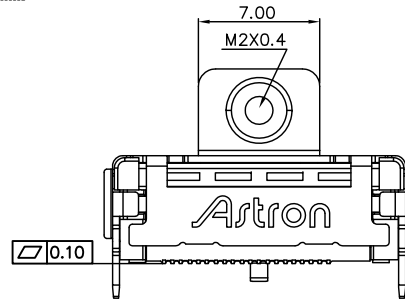
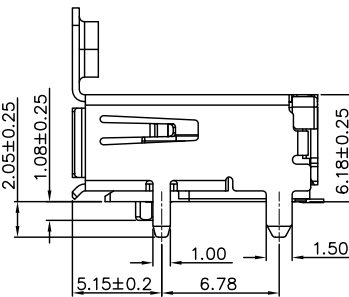
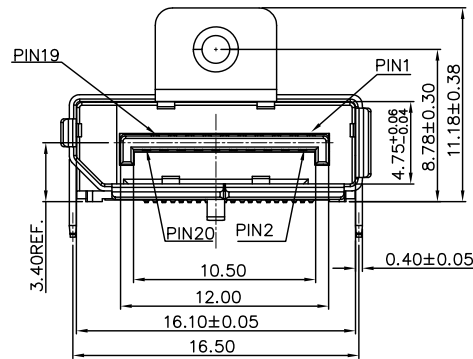
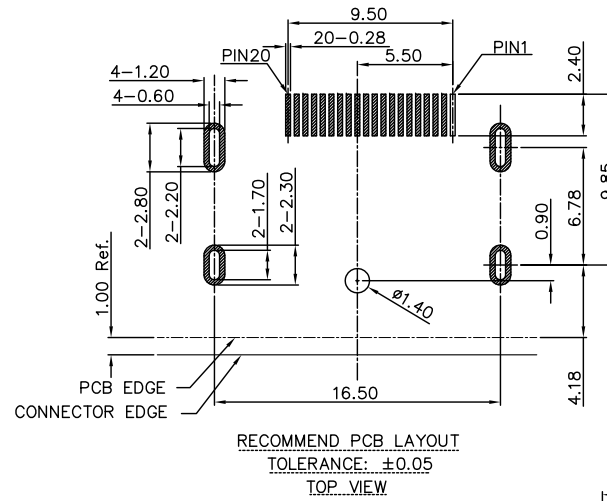
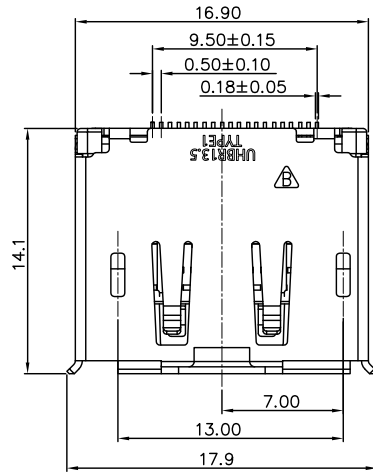

REV.	DESCRIPTION	DATE
A	N22'11003	Nov.09, 2022
B	N23'02003	Feb.23, 2023

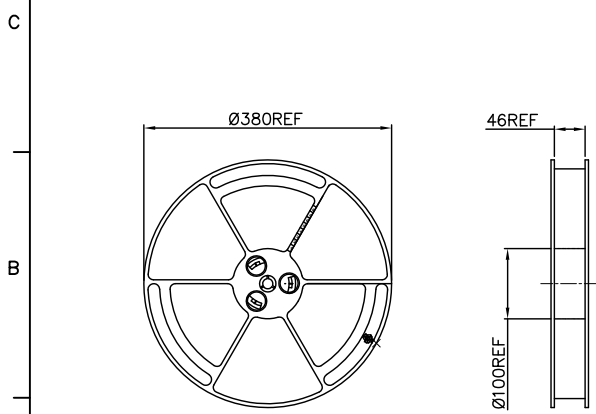
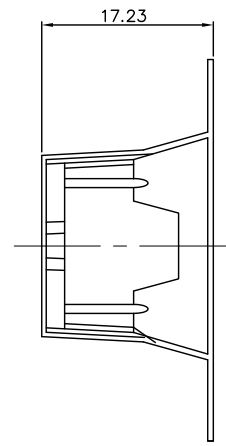
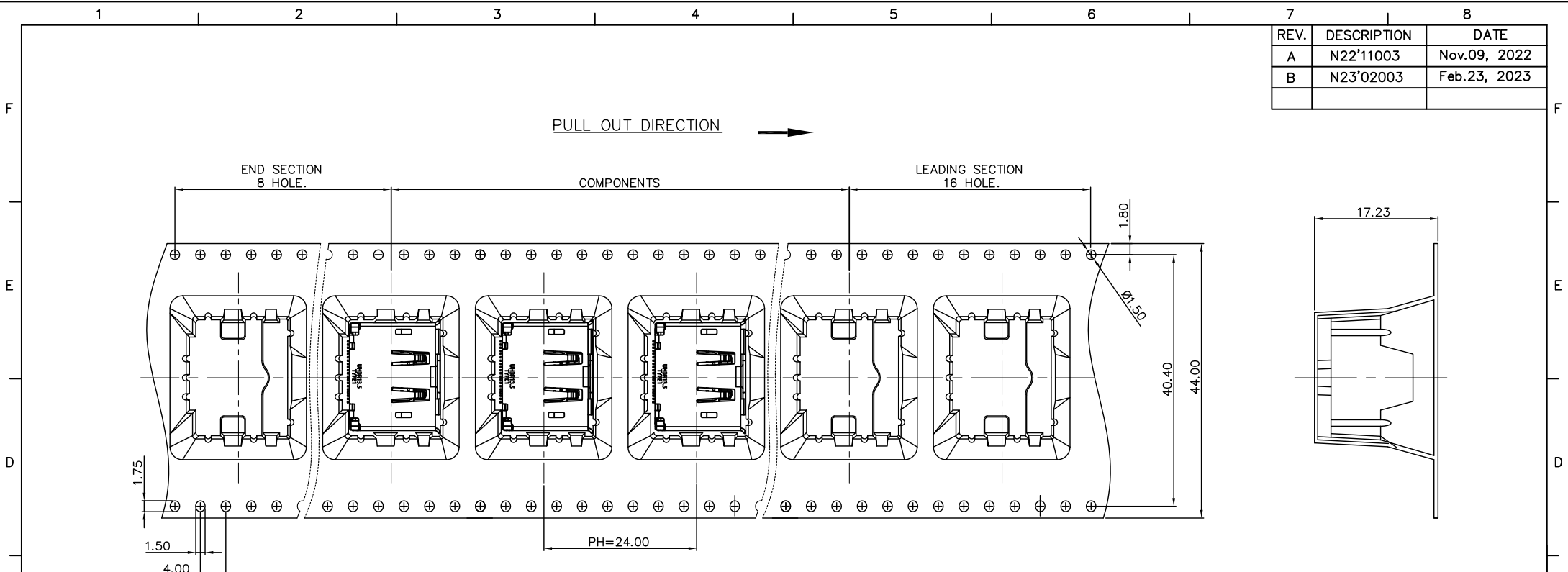

REEL FOR CARRIER TAPE

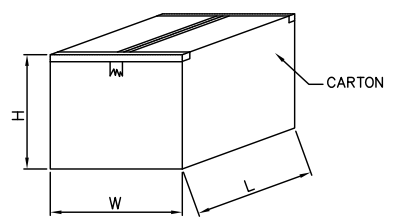
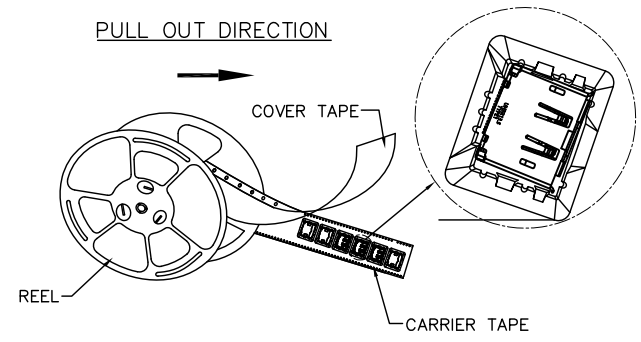

**TAPE & REEL PACKAGE :
MATERIALS**

- 1. CARRIER TAPE: POLYSTYREN (PS)
- 2. COVER TAPE: POLYSTYREN (PS)
- 3. REEL: POLYSTYREN (PS)

QUANTITY

- 1. 250PCS PER REEL
 - 2. 5 REEL PER CARTON(1250PCS PER CARTON)
- (CARTON : L=400mm, W=400mm, H=270mm)

TOLERANCE .0=±0.25 .00=±0.15 .000=±0.05 ANG.=±3°	DRAWER <i>Shen</i>	 ASTRON TECHNOLOGY CORP.
	CHECK <i>Hony</i>	
APP'D <i>Hony</i>	NAME Enh FS DP Receptacle Connector (Type1), SMT TYPE (SCREW THREAD M2)-8.78mm	
PRODUCT SPEC. _____	DRAW NO. R699FA20-XN102D-H	
UNITS : mm	SHEET 2 OF 2	REV. B
SCALE NONE	SIZE A4	