

REV.	DESCRIPTION	DATE
A	RELEASE	Oct.15, 2018

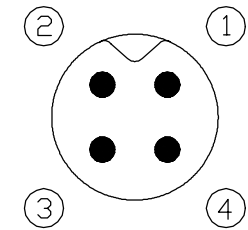
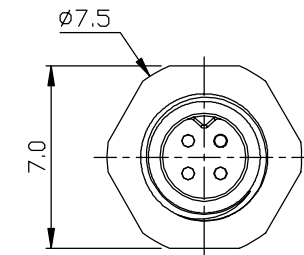
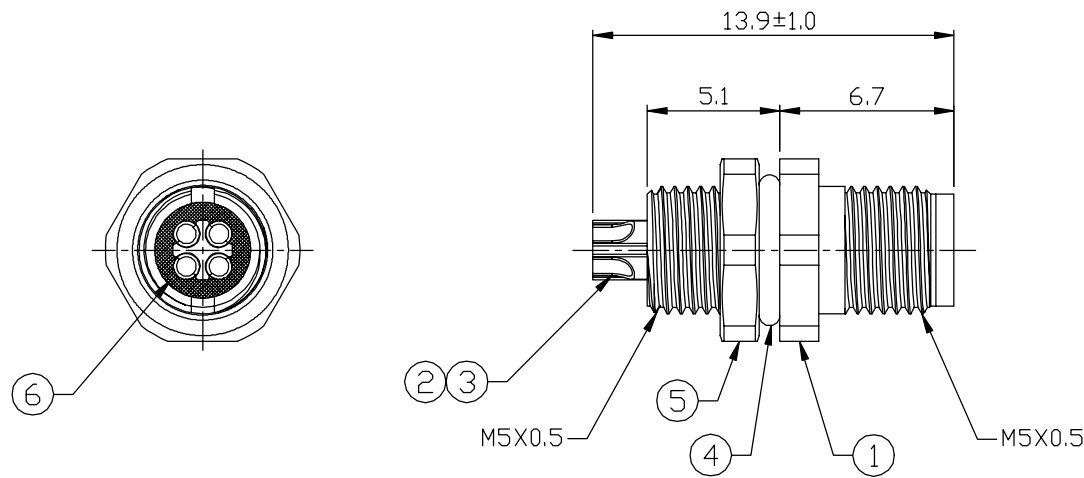

Front View  
Pin Assignment

Notes: (Unless Otherwise Specified)

1. Waterproof Rate: IP67.
2. Recommend Panel Thickness: 0.8 To 2.0 mm.
3. Recommend Torque: 5~6 Kgf-cm.
4. Durability: 100 Cycles Min.
5. DWV: 900 Vrms.
6. Rated Voltage: 60V AC/DC.
7. Insulation Resistance: 100 MΩ Min.
8. RoHS Compliant.

Materials:

6	Glue	Epoxy Color: Black	
5	Hex Nut	Copper Alloy Finish: Ni Plated	1
4	O-Ring	NBR Color: Black	1
3	Contacts	Copper Alloy Finish: Au Plated	4
2	Housing	Thermoplastic Color: Black	1
1	Metal Body	Copper Alloy Finish: Ni Plated	1
Item	Part Name	Material / Finish	Q'ty

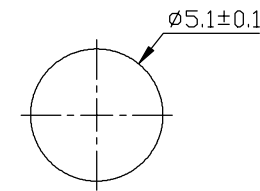

Recommend  
Panel Cut-Out

Part Number Information:

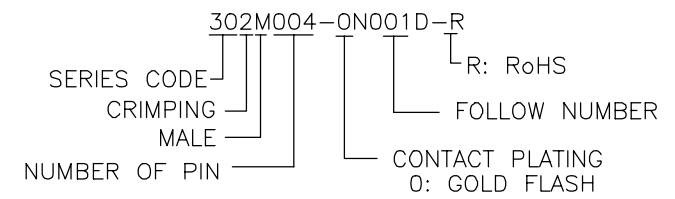

<b>TOLERANCE</b> .0=±0.25 .00=±0.15 .000=±0.05 ANG.=±3°		<b>DRAWER</b> <i>EXER</i>	 ASTRON TECHNOLOGY CORP.
 UNITS : mm		<b>CHECK</b> <i>JYUNY</i>	
<b>SCALE</b> NONE		<b>SIZE</b> A5	<b>DRAW NO.</b> R302M004-0N001D-R
<b>SHEET</b> 1 OF 1		<b>REV.</b> A	