

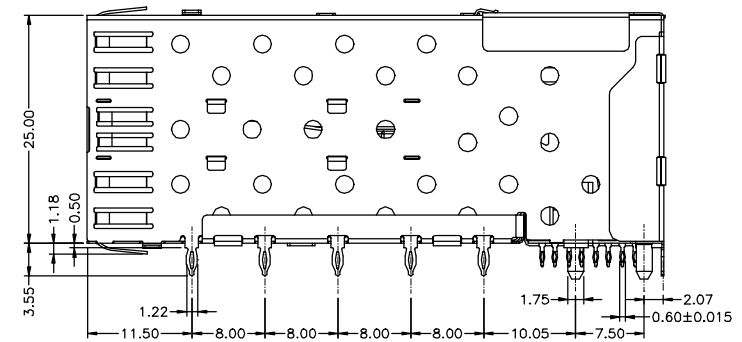

| REV. | ECN NO. | DATE         |
|------|---------|--------------|
| A    | RELEASE | Mar.14, 2014 |

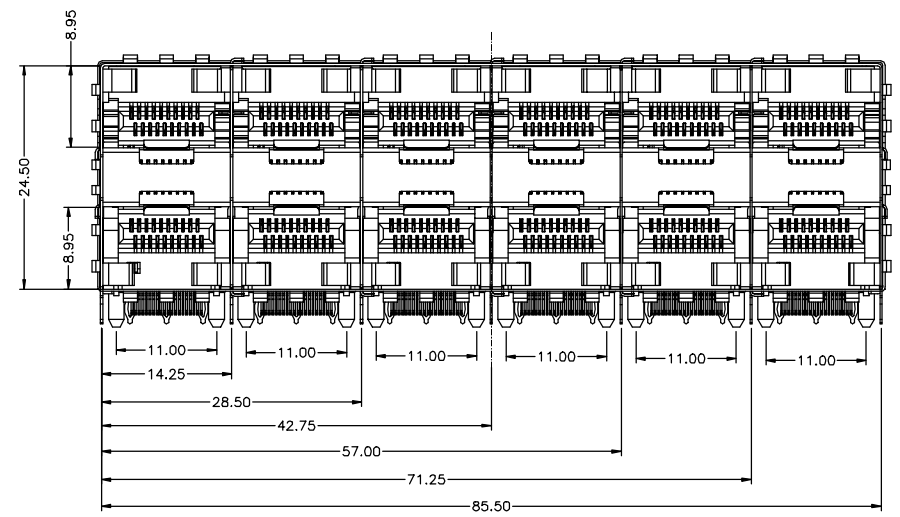
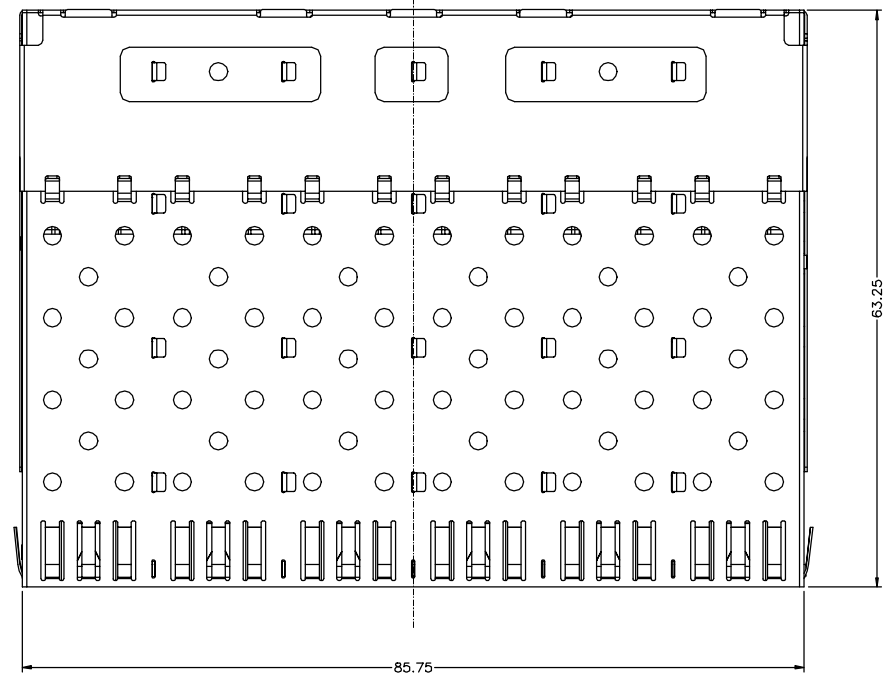

|                                                                                                     |  |                              |                                                                                                                         |                                                                  |
|-----------------------------------------------------------------------------------------------------|--|------------------------------|-------------------------------------------------------------------------------------------------------------------------|------------------------------------------------------------------|
| <b>TOLERANCE</b><br>.0=±0.25<br>.00=±0.15<br>.000=±0.05<br>ANG.=±3°                                 |  | <b>DRAWER</b><br><i>Chen</i> | <br><b>ASTRON TECHNOLOGY CORP.</b> |                                                                  |
| <br>UNITS : mm |  | <b>CHECK</b><br><i>Stony</i> |                                                                                                                         | <b>NAME</b><br>W/O LIGHT PIPES SFP PLUG<br>2 BY 6 CAGE+CONNECTOR |
| <b>SCALE</b><br>NONE                                                                                |  | <b>SIZE</b><br>A4            | <b>APP'D</b><br><i>Stony</i>                                                                                            | <b>DRAW NO.</b><br>R7960240-XN001D-R                             |
| <b>SCALE</b><br>NONE                                                                                |  | <b>SIZE</b><br>A4            | <b>PRODUCT SPEC.</b><br>—                                                                                               | <b>REV.</b><br>A                                                 |
| <b>SHEET</b><br>1 OF 3                                                                              |  | <b>REV.</b><br>A             |                                                                                                                         |                                                                  |

|      |         |              |
|------|---------|--------------|
| REV. | ECN NO. | DATE         |
| A    | RELEASE | Mar.14, 2014 |

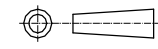
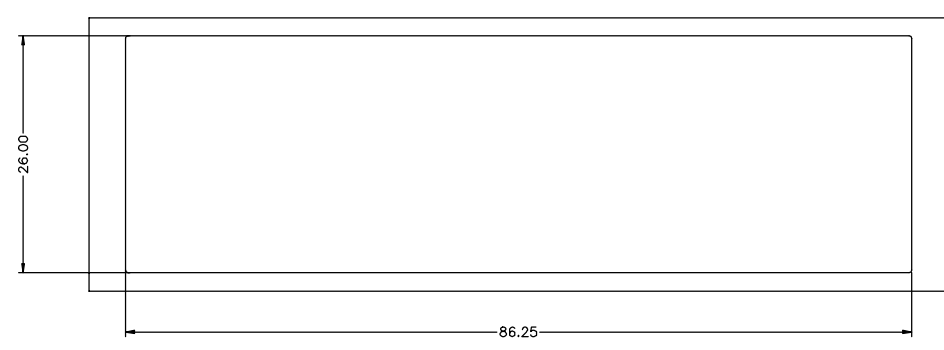

BEZEL CUT-OUT CENTER SPACING DETAIL  
BEZEL THICKNESS:0.8-2.6

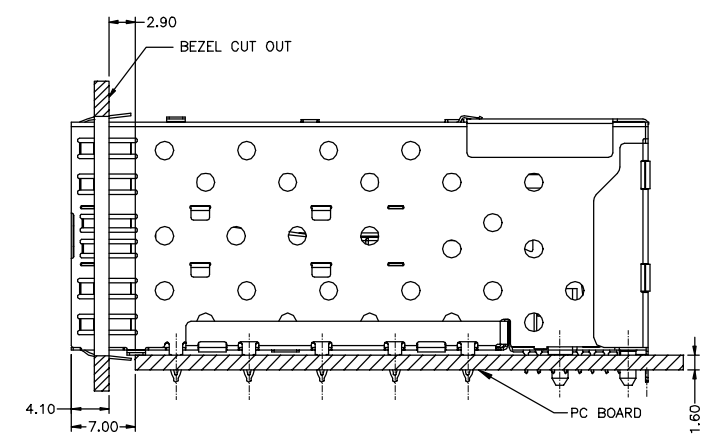

**MATERIALS**

1. HOUSING : LCP (UL94V-0), BLACK.
2. SPACER: LCP (UL94V-0), BLACK.
3. TERMINAL: PHOSPHOR BRONZE,  
GOLD PLATED ON CONTACT AREA,  
TIN PLATED ON SOLDER TAIL,  
NICKEL PLATED OVER ALL.
4. TOP SHELL: BRASS, NICKEL PLATED OVER ALL.
5. MIDDLE SHELL: STAINLESS STEEL,  
NICKEL PLATED OVER ALL.
6. BOTTOM SHELL: BRASS, NICKEL PLATED OVER ALL.
7. BACK SHELL: BRASS, NICKEL PLATED OVER ALL.

**SPECIFICATION**

1. CURRENT RATING : 0.5A. MAX.
2. VOLTAGE RATING : 120V.
3. INSULATION RESISTANCE : 100MΩ MIN.  
AT 300V DC.
4. CONTACT RESISTANCE : 30mΩ MAX.
5. OPERATING TEMPERATURE : -40°C TO +85°C.
6. DURABILITY : 100 CYCLES.

**PART NUMBER INFORMATION**

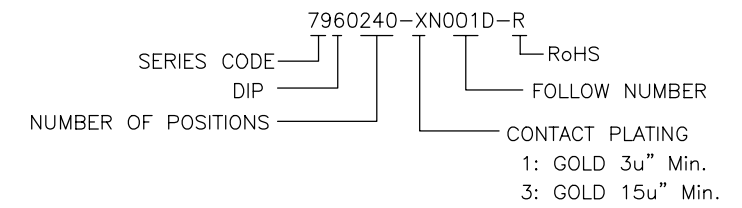

|                                                              |  |                       |  |                               |
|--------------------------------------------------------------|--|-----------------------|--|-------------------------------|
| TOLERANCE<br>.0=±0.25<br>.00=±0.15<br>.000=±0.05<br>ANG.=±3° |  | DRAWER<br><i>Chen</i> |  | <br>ASTRON TECHNOLOGY CORP.   |
| <br>UNITS : mm                                               |  | CHECK<br><i>Stony</i> |  |                               |
| SCALE<br>NONE                                                |  | SIZE<br>A4            |  | DRAW NO.<br>R7960240-XN001D-R |
| SHEET<br>2 OF 3                                              |  | REV.<br>A             |  |                               |

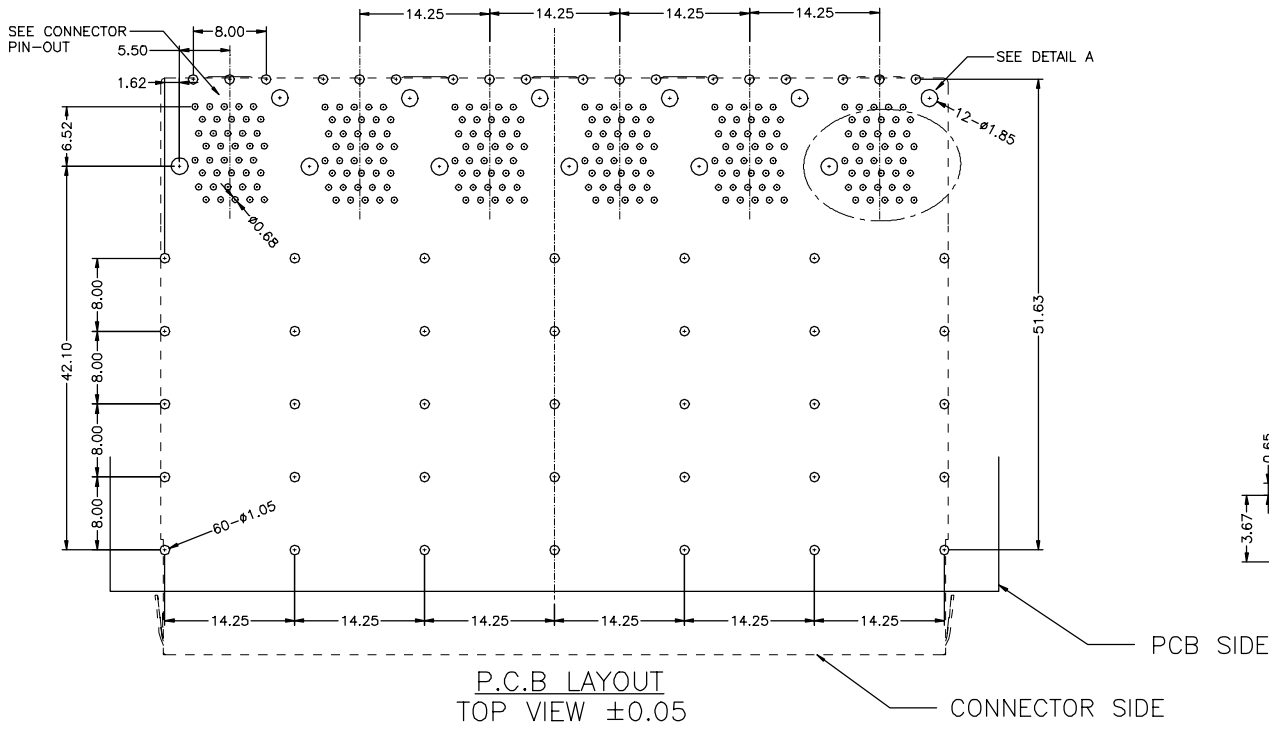

| REV. | ECN NO. | DATE         |
|------|---------|--------------|
| A    | RELEASE | Mar.14, 2014 |

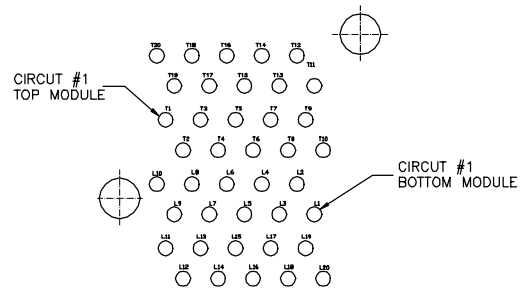
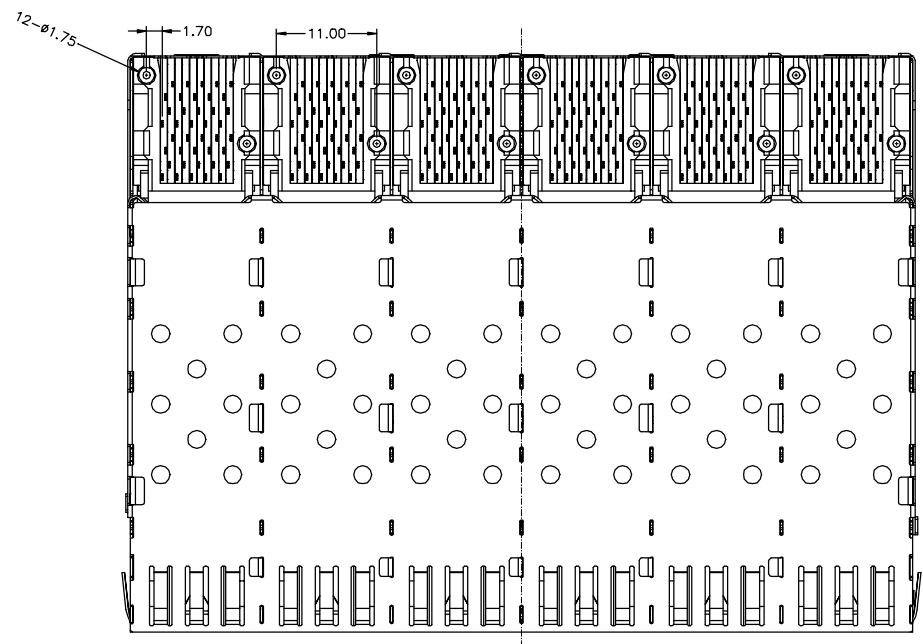
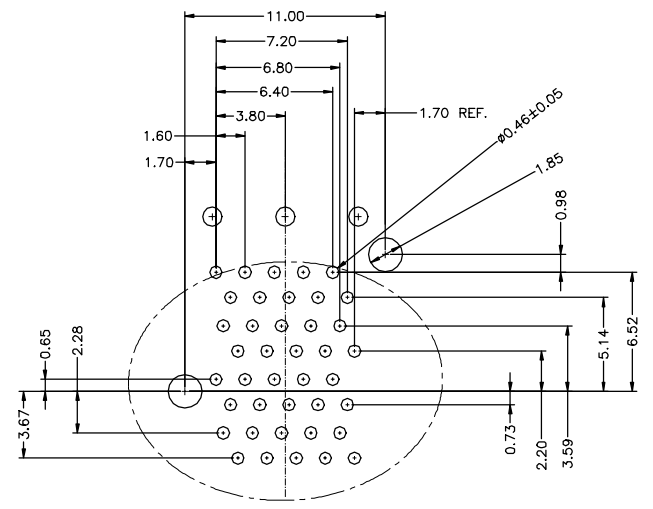

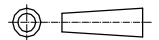
|                                                                                                     |  |                       |  |                                                                                                                  |
|-----------------------------------------------------------------------------------------------------|--|-----------------------|--|------------------------------------------------------------------------------------------------------------------|
| TOLERANCE<br>.0=±0.25<br>.00=±0.15<br>.000=±0.05<br>ANG.=±3°                                        |  | DRAWER<br><i>Ehen</i> |  | <br>ASTRON TECHNOLOGY CORP. |
| <br>UNITS : mm |  | CHECK<br><i>Stony</i> |  |                                                                                                                  |
|                                                                                                     |  | APP'D<br><i>Stony</i> |  | DRAW NO.                                                                                                         |
| SCALE<br>NONE                                                                                       |  | PRODUCT SPEC.<br>---  |  | R7960240-XN001D-R                                                                                                |
| SIZE<br>A4                                                                                          |  | SHEET<br>3 OF 3       |  | REV.<br>A                                                                                                        |